

Geneva Scottish Country Dance Club

Programme - Spring Dance - Saturday 6th April 2019

Hooper's Jig 3/4L · J32

- 1- All clap, 1c cross Rsh and cast off one (2c up) ; 1c+3c RHA
- 9- All clap, 1c cross back Rsh, cast up to own place (2c down) ; 1c+2c LHA
- 17- 1M+3W change places RH | 1W+3M change RH, while{2} 1M+3W dance a Rsh loop ; 1M+3W cross back RH while{2} 1W+3M loop | 1W+3M cross back LH, 1W to 2pl while{2} 1M casts to 2pl (2c up)
- 25- 2c+1c R&L

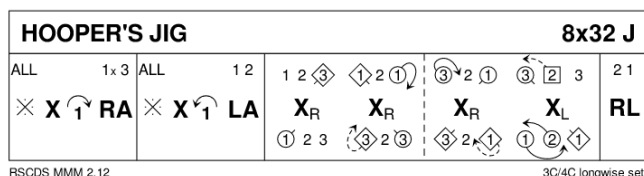

Barbara's Strathspey 3/4L · S32

- 1- 1c set | cast (2c up) ; 1/2 Fig8 L (2,1x,3)
- 9- All set | 1c cross Rsh ; 1c+3c turn RH 1 1/2 (to 1,2,3 on M side, 2,3,1 on W side)
- 17- 3C Bourrel: 2W+3M chase cclw half round to midline while{4} 1M+3W & 2M+1W set adv | turn BH 3/4 and pivot R, all facing P on midline (3,1,2) ; All set | All C turn BH 3/4 to sidelines
- 25- All chase clw 1/2 round ; all turn P RH 1/2 and twirl R to (2,1,3)

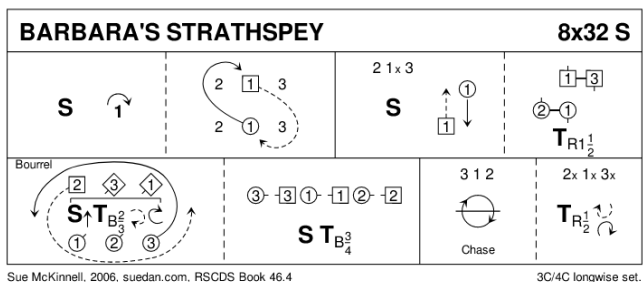

Ramadan-ce 3/4L · R32

- 1- 1c+2c+3c Inveran Reels (1,2,3)
- 9- 1c cross RH | cast (2c up) ; Turn RH to face 1cnr
- 17- 1c+1cnrs pass Rsh | cnrs turn RH 1/2 and cast away as 1c meet and pass Rsh to face 2cnrs ; repeat with 2cnrs (3x,1x,2x)
- 25- 1/2 Reels3 across, 1c Lsh to 3cnr ; 1/2 Reels3 on the sides, 1c Rsh to 4cnr (2,1,3)

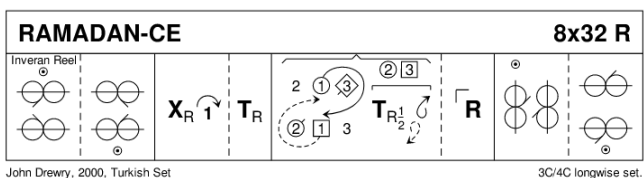

Links with St Petersburg 3/4L · J32

- 1- 1c+2c S&Link, finish 2c facing 1c NHJ ; S&Link to (2x,1x,3)
- 9- 1c, 2c following, dance down {3}, change sides with NHJ, W passing above M and under his arm, 2c+1c dance up to (2,1,3), 2c facing out
- 17- 2c turn 1c EH on sides ; 1c turn 3c EH, 1c finish BtoB facing 1cnr
- 25- SetH&G , petronella to (2,1,3)

LINKS WITH ST PETERSBURG				8x32 J	
1 2 S & LINK		2x 1x N L under M arm	2 1 N		
				S S S T _◇	

Malcolm Brown, 2009, RSCDS Book 46.10

3C/4C longwise set.

The Robertson Rant 4S · S80

- 1- All Circle8 and back
- 9- Double L chain (women 1/2 RHA, turn opposite M LH ; 1/2 RHA, turn P LH, to own places)
- 17- 1c+3c Reel4, (W pass left shoulder, M set on [17-18], at the end W slow down and M speed up, face and acknowledge P and pull back inner shoulder to face corners.
- 25- All set to corner H.Schottische ; turn cnr BH twice
- 33-48 2c+4c repeat [17-32]
- 49- Women Circle4 L (at end pull back Rsh to face out) ; set to and turn P BH.
- 57- Men circle4 R, pull back Lsh ; set to and turn P BH.
- 65- G-Chain (one step per hand)
- 73- Promenade cclw round the set in Allemande hold, M bring W into middle of set and hold RH for bow and curtsy

THE ROBERTSON RANT						80 S	
8 WOMEN	ALL RA	ALL T _L	R	1 3 Men set to start	ALL HS T _{B2}	2 4 R	16 bars
WOMEN 4	ALL S T _B	MEN 4	ALL S T _B	ALL CHAIN	ALL PROM (Allemande Hold)		

Mrs Douglas Winchester, 1949, RSCDS Book 39.8

4C/4C square set.

Trip to Timber Ridge 3/4L · R32

- 1- 1c turn RH | cast (2c up) ; 1W+2c & 1M+3c RHA, 1c facing 1cnrs at end
- 9- Corners Pass and Turn, on [16] 1c pull Rsh back to finish BtoB in centre facing opposite side
- 17- DTr, on [23-24] 1c Petronella turn to 2pl (2,1,3)
- 25- Circle 6 and back

TRIP TO TIMBER RIDGE				8x32 R	
		Corners Pass & Turn			
				2 1 3	6

Linda Henderson, 2010, RSCDS Book 52.12

3C/4C longwise set.

The Bees of MaggieKnocker 4/4L · J32

- 1- 1c cross RH | cast off (2c up) ; 1c+3c RHA, finish as pairs 1M+3W & 3M+1W facing out on W/M side in promhold
- 9- Pairs+ 2c+4c Rsh 1/2Reels3 on sides ; pairs meet & take P in promhold for Lsh 1/2Reels3 on sides
- 17- Meet and repeat (as pairs Rsh 1/2Reels3 ; with P Lsh 1/2Reels3)
- 25- 1c (passing inside) turn 3c 1 1/2 Easy Hand ; 1c cross and passing inside turn 4c EH 1 1/2 (to 2,3,4,1)

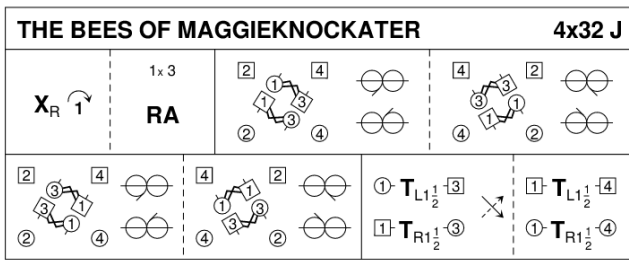

Sands of Morar 3/4L · S32

- 1- 1c Fig8 round 2c, giving hands
- 9- All Mirror Reels3 on own side, 1c starts in, join hands on meeting P
- 17- 1c turn BH | 1c dance to 3pl NHJ while{4} 2c+3c continue reel to top and follow behind 1c ; 3c+2c+1c set facing down | 1c cast to top, 2c+3c following to finish (1,2,3)
- 25- 1c+2c Tourbillon (1c+2c turn P BH 1/2, opening out to one place clw in the square (1c to W side, 2c to M side) | 1c set to 2c ; repeat figure (to 2x,1x) | 2c+1c cross RH) (2,1,3)

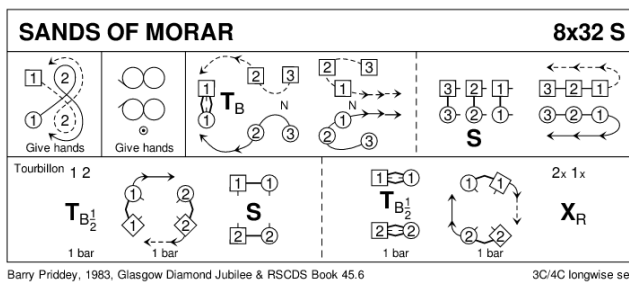

The Ambassadors' Reel 3/4L · R32

- 1- 1c dance between 2c and cast up ; 1/2 Fig8 down round 2c,
- 9- 1c dance down between 3c (2c up) ; cast up, 1/2 Fig8 down round 3c (2,1,3)
- 17- 1c turn 1crr RH, pass Rsh, turn 2crr RH, pass Rsh into
- 25- Circle6 and back (2,1,3)

Deviser's Note: 1c can choose handing freely ; the timing is fluid, the barring only an approximation

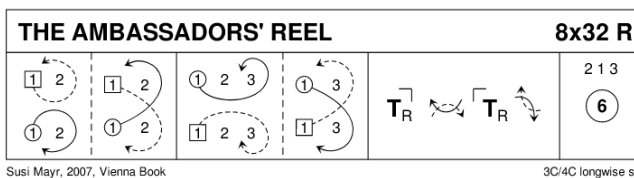

Dinner

The Findlays' Jig 3/4L · J32

- 1- 1c lead down the middle and up, 2c+3c step in for
- 9- 1c+2c+3c Allemande (to 3,2,1)
- 17- 1c long cast to 1pl (3c+2c down) ; 2c repeat (1c+3c down) (2,1,3)
- 25- Circle6 and back

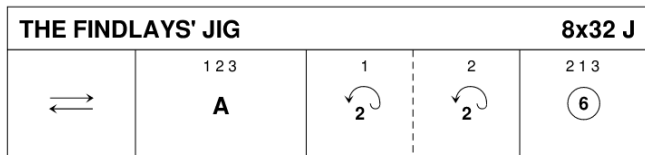

R Goldring, 2000, 14 Social Dances for 2000

3C/4C longwise set.

La Fidèle de Lausanne 3T · S32

- 1- 1c turn BH | dance down NHJ, out through side cpls ; cast up own side to face P | turn BH & open out
- 9- All S&Link to face P ; ½ interlocking Reels4{3} & ½ turn P LH
- 17- Bourrel-like sequence: set adv passing P LSh | ½ turn next person BH & twirl away ; set adv passing LSh | turn P RH ending with W facing out (1,2,3)
- 25- Triangular Schiehallion (clover leaf) reels to (3,1,2)

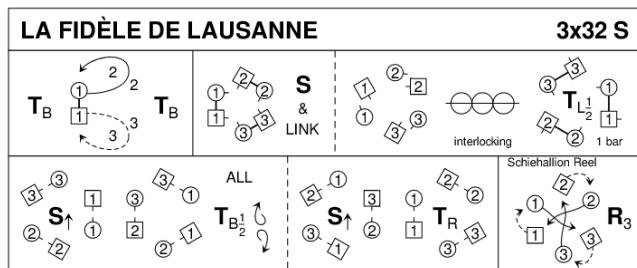

Murrough Landon, 2018, <https://my.strathspey.org/u/murrough/FidèleDeLausanne.pdf>

3C/3C triangular set.

The Australian Ladies 3/4L · R32

- 1- 1c cross RH | cast off two (2c+3c up) ; 3c+1c RHA
- 9- 1c lead to top, cross and cast to 2pl (3c down) ; 2c+1c LHA (2,1,3)
- 17-32 2c+3c (>corners<) set and change place RH four times following the track of R&L (3M&2W make polite turns) **while**{16} 1c cross (across or up/dn) RH and cast R round the corner four times.

Note by the deviser in TacTalk of jan. 1986: on [17-32] the corners set »as written«; they do not split the setting as is customary in »J.B. Milne«. Devised in May 1967 in New Zealand by Bob Campbell of Canada for Jean Conway, Elma See, Lorraine Dyll, and Margaret Gray of the Newcastle (Australia) Colleges Strathspey and Reel Club.

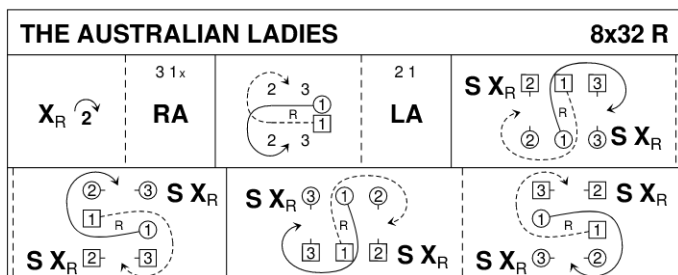

Campbell, 1967, Glasgow Assembly

3C/4C longwise set.

The Aviator 3/4L - J32

- 1- 8 1s lead down the middle; on bar 4, 1M crosses 1W in front of him. | 1W, followed by 1M, cast behind 4M and 3M to 2nd place.
- 9-16 1s, with W leading, half dolphin reel on 1st diagonal. | 1M dance 2nd half reel of 3 on 1st diagonal, while 1W and 3M turn LH.
- 17-24 1s, with M leading, half dolphin reel on 2nd diagonal. | 1W dance 2nd half reel of 3 on 2nd diagonal, while 1M and 3W turn LH.
- 25-32 In {6}, 1W cast up round 2M and across the top, 1M dance up round 2W, both cast behind 2W to 2nd place as 2s step up and face in; 2s, 1s & 3s set.

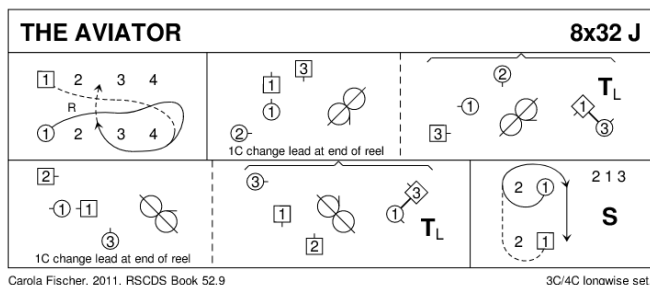

Bridge of Nairn 3/4L - S32

- 1- 1c cast off 2 places, lead up to the top ; cross over and cast off one place (2c up), meet NHJ facing 2W
- 9- 1c set to 2W, turn inwards, set to 3M ; veer left and set to 3W, turn inwards, set to 2M, finish facing 1cnrs (1M pulls back Rsh).
- 17- 1c turn corner, P ; corner, P finishing (2,1x,3)
- 25- All A&R ; 1c turn BH 1½ times (2,1,3)

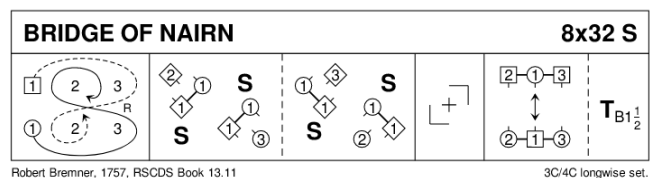

Summer Wooing 3/4L - R32

- 1- 1c+2c circle 4 to the left ; 1c+2c chase clw ½-round to finish on opposite sides, 2c facing 1c (2x,1x,3)
- 9- Rsh Reels 3 on sides
- 17- 1c, followed by 2c lead down the middle {3}, (2c split for) 1c+2c lead up {3} | and cross to own side RHJ, the W passing below the M and under the joined arms, into
- 25- 1c+2c Poussette (2,1,3)

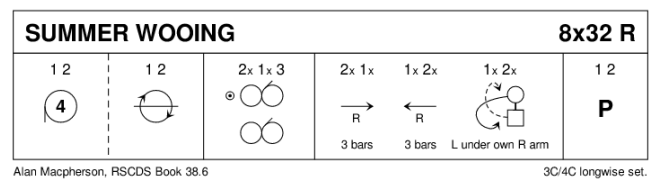

Vintage Simon 5/5L · J32

- 1- 1c+5c turn RH 1/2 | Chase clw (1M & 5W leading) behind sideline to 4pl/2pl | turn P RH to face 1cnr while {8} 3c set | dance up (2c+4c step down) ; and curve into 1pl | set (3,5,2,1,4)
- 9- Corners Chain with setting: 1c&5c change place RH with 1c | cnrs turn LH as 1c+5c set ; change back with cnr | turn LH 1/4 to face 2cnr
- 17- Repeat with 2cnr, at end 5c+1c turn P LH to finish on midline facing own side, M above W (3,5,2,1,4)
- 25- RHA in pattern 3-4-3 ; 5c+1c BiL on midline | turn P LH 3/4 to (3,5,2,1,4)

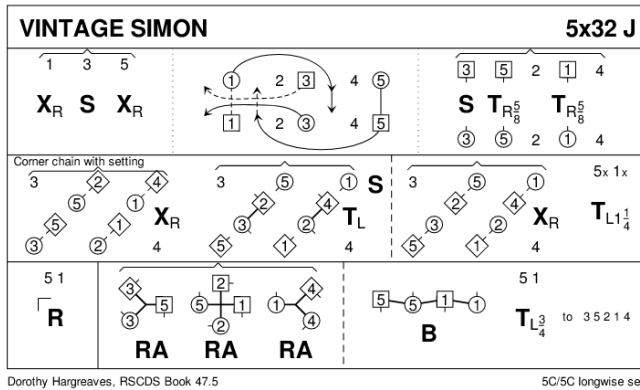

The Gentleman 3/4L · S32

- 1- 2c step up as 1c turn BH to face P between them in line4 across | 1c+2c set, 1c advancing and passing on the second step ; 1/2Reel4, at end 1c pass LH to face down NHJ
- 9- 1c dance down to face P between 3c, repeat set and 1/2Reel4 with 3c, finish between 3c on own side LHJ
- 17- 1c lead to top, cross and cast to 2plx ; 1/2Reels3 across, Rsh to 4cnr (W up, M dn) (to 2,1,3)
- 25- 2c+1c Poussette.

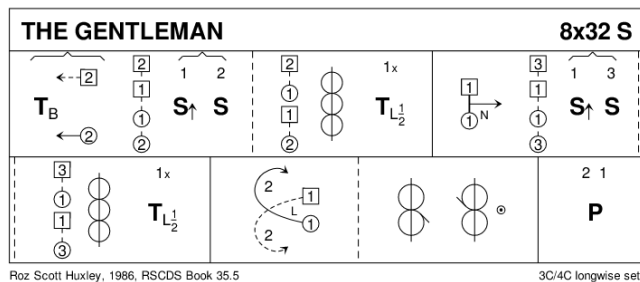

The Dancing Man 3/4L · R32

- 1- 1c+2c turn RH to places ; 1c+2c RHA (1,2,3)
- 9- Parallel Rsh Reels3 on the sides, but 1c+2c extend reel to form line across (2M, 1M, 2W, 1W), 3c ends in 3pl
- 17- 1c+2c 3/4 Reel4 across (2W,2M,1W,1M) | pass P Rsh to own side (2,1,3)
- 25- Circle6 and back

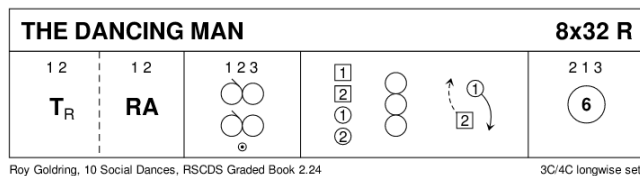

Extras

Pelorus Jack 3/4L · J32

- 1- 1c cross RH, cast (2c up) ; 1c+3c RHA, finish 1M facing 1cnr, 1W behind him
- 9- 1c in tandem +1cnrs ½ diagonal Reel3, Rsh to 3W (1M & 1W loop R singly for lead change, so 1W now leads P) ; ½ diagonal Reel3, Rsh to 2W (+ lead change)
- 17- Continue pattern twice
- 25- 2c+1c LHA ; 1c turn LH ½ | all set (2,1,3)

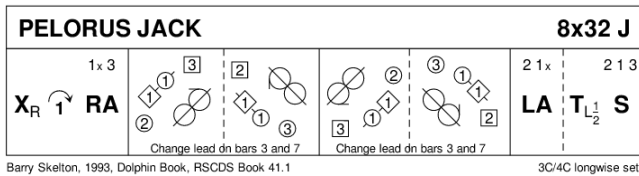

Chasing the Eclipse 3/3L · S32

- 1-8 1C set, dance NH down the center + cast up to 2pl & cross to face 1cnr.
- 9-16 Reel 3 on sides - 1C pass 1cnr Rsh to begin.
- 17-24 1C+1cnr set , 1C spiral Rsh rnd ptnr to face 2cnr ; 1C+2cnr set , 1C spiral Rsh to face out 2pl own side.
- 25-32 All dance Chaperoned Chain Progression. End 3 1 2.

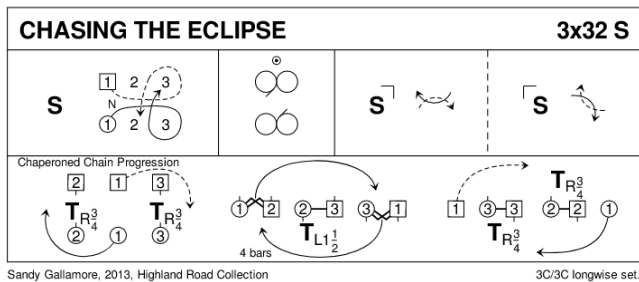

Flowers of Edinburgh 3/4L · R32

- 1- 1W followed by 1M casts off 2, 1W crosses below 3c and casts up M side while} 1M dances up the middle, both to P's place {6} | 1c set
- 9- 1c repeat with 1M casting, finishing in original places
- 17- 1c lead down the middle and up
- 25- 1c+2c Poussette

